

# TIRED OF REPLACING YOUR SHINGLE ROOF?

Why Business Owners & Institutions  
Choose Metal Roofing



[www.mcelroymetal.com](http://www.mcelroymetal.com)

# INTRODUCTION

---

If you're like most successful building owners we work with, the number of things on your "to-do" list can be almost overwhelming. So, of course, the challenge becomes focusing on those that move the needle the most. While maintenance of your building is undoubtedly necessary, it's rarely an item that business owners enjoy for several reasons: for example, roof replacement causes interruption to daily business operations, which can affect productivity, damage to finished goods, and even safety. Beyond that, the costs associated with roof replacement are often unexpected and certainly don't move the needle as a different capital investment might like adding new products, headcount, or technology. Consequently, we find that most building owners dread the recurring hassle and expense of replacing a shingle roof.

Let's face it; outside of their price point, conventional shingles offer little value. Historically building owners have accepted that shingles provide a relatively short-term roof solution that will most likely need to be replaced well before the stated limited warranty life. However, over the last few years, the tides have turned. In part because metal roofing offers a [50-60 year service life](#) lasting 2-3 times longer than shingles. Beyond service life though, metal roofing offers many other benefits, including:

- Low maintenance
- Energy-efficiency for lower utility expense
- Excellent host for solar energy
- Environmentally friendly with high recycled content
- Highly resistant to Mother Nature's elements and fury
- And, metal roofing looks great - adding curb appeal to any project

If roof replacement is on the horizon for you and you're simply worn out from replacing shingles every 12 to 15 years, we're here to help. We developed this eBook to provide building owners with information about the features and benefits of metal roofing systems so you can make an informed decision when it's time to buy a new roof. Our goal is to make every building owner's new roof their last roof.

# TABLE OF CONTENTS

---

RECOVER SNAPSHOT ..... 3

ADVANTAGES OF METAL ROOFING ..... 4

INSTALLATION APPROACHES-REMOVE & REPLACE VS. RECOVER..... 10

METAL ROOFING OPTIONS.....12

METAL PANEL STYLES.....18

PROJECT SPOTLIGHTS .....21

CHOOSING A PARTNER.....22

SUMMARY .....24

# RECOVER SNAPSHOT

Historically, when a shingle roof was at the end of its service life, building owners went on autopilot and reached out to roofing contractors to get quotes. Today, more and more business owners recognize the many benefits of metal and opt for a long-term solution to replace their worn-out shingle roofs.

One of the typical early questions when comparing shingle and metal roofing is cost. While it is generally accurate to state that metal roofing will cost more than shingles initially, as soon as shingles are replaced once (usually at 12-15 years), metal roofing becomes the more economical roof system. It's all about the difference between first cost and life cycle costs. If you're interested in learning more about the cost comparison between metal roofing and shingles, [check out this blog post.](#)

The benefits of metal roofing reach far beyond cost savings, though. We will take a more detailed look at the many features and benefits of metal roofing throughout this eBook. Below is a quick-reference table highlighting some performance differences between conventional shingles and metal roofing.

	SHINGLE ROOF	METAL ROOF
AESTHETICALLY PLEASING	NO	YES
LONG SERVICE LIFE	NO	YES
LOWER UTILITY EXPENSE	LIMITED	YES
HIGH RECYCLED CONTENT	NO	YES
RECYCLED AFTER SERVICE LIFE	LIMITED	YES
FIRE-RESISTANT	LIMITED	YES
HAIL-RESISTANT	LIMITED	YES
HIGH WIND-RESISTANCE	NO	YES

# ADVANTAGES OF METAL ROOFING

- Long Service Life
- Excellent Solar Host
- Fire, Hail & Wind Resistant
- Lower Utility Expense
- Recycled After Service Life
- Aesthetically Pleasing

## LONG SERVICE LIFE

When it comes to longevity and service life, it's hard to beat metal roofing. A recent white paper published by the Metal Construction Association indicates metal roofs made from Galvalume substrates **could last 60 years or more.** Just think, that means that you could be faced with the business interruption, mess, and cost just one time over the life of your business instead of dealing with it every 12 to 15 years. That in itself is a difference-maker to most busy business owners.

Utilizing a high-performing paint system is also key to maintaining a great-looking roof year after year. Fluoropolymer (Kynar 500®) coatings are long recognized as the industry's superior coating for long-term performance. If you're not familiar with Kynar coatings, you can **[read more about them here.](#)**



## METAL ROOFING REDUCES UTILITY EXPENSE

When compared with other roofing materials, metal roofing offers lower utility expenses. Cool roof pigments and Above Sheathing Ventilation (ASV) are two ways business owners can achieve energy savings.

Advances in coating technology enable paint manufacturers to add reflective pigments to coating systems. These coating systems, referred to as Cool Metal Roofing, offer high reflectivity and high thermal emittance.

Reflectivity measures the amount of energy reflected away from the roof's surface, and thermal emittance is the measure of a panel's ability to release heat that it has absorbed. Reflectivity and emittance work together to lower utility loads because less of the sun's energy gets absorbed into the roof system, attic area, and living/office space below. Studies have shown that a cool metal roof can save a building owner as much as 20% in their cooling energy costs. Conversely, conventional shingles absorb much more of the sun's energy resulting in higher air conditioning loads.

# ADVANTAGES OF METAL ROOFING

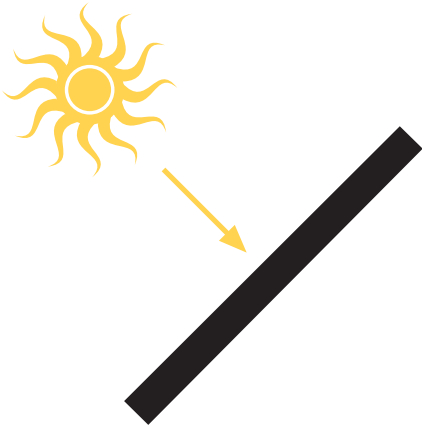

**Energy-Absorbing  
Black Asphalt Roof**

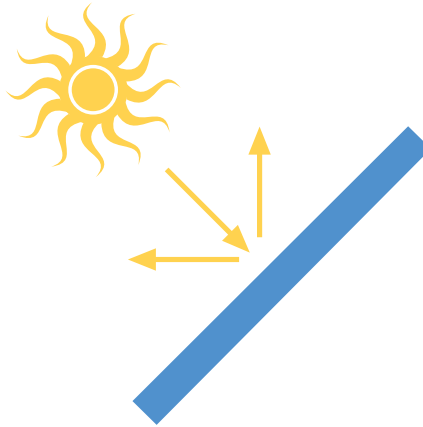

**Reflective Roofs  
Reflect Sun's Energy**

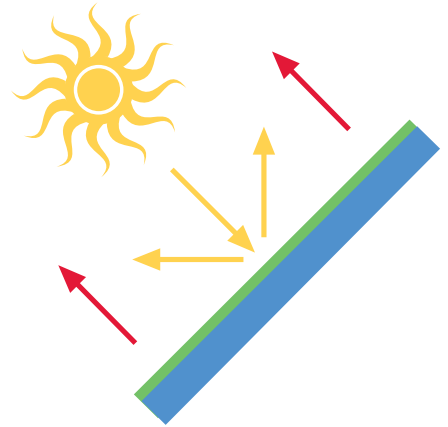

**Re-Emissive  
Metal Roof Surface**

Even utility companies have become interested in cool metal roofing because it can help to reduce the peak demand for electricity during the afternoon hours in the summer months. Reduction of demand during those hours can prevent power disruptions. From an environmental point of view, cool metal roofing can also help mitigate a phenomenon known as the "heat island effect," where urban areas experience higher air temperatures due to the abundance of non-reflective roofing materials, like shingles.

Above Sheathing Ventilation (ASV) means adding a ventilated airspace between the metal roofing and the substrate below. The airspace enables energy to move and vent into the atmosphere rather than get absorbed into the building structure, which reduces utility load.

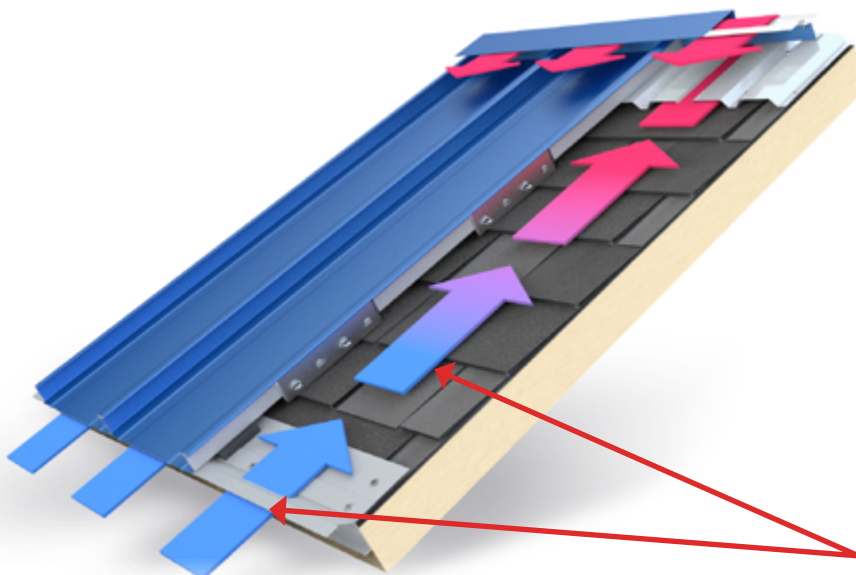

3/4" airspace  
between shingles  
and metal roof

# ADVANTAGES OF METAL ROOFING

To better understand the benefits of ASV, [check out this video](#) comparing attic temperatures of four different mock-up, systems exposed to the summer heat in Houston, Texas. The mock-up with ventilated airspace had an attic temperature of only 5 degrees higher than ambient air. Conversely, the temperature of the shingle roof was nearly 40 degrees higher. According to the Department of Energy, heating, cooling, and ventilation costs amount to 35% of energy costs for an average building. Therefore, adding above sheathing ventilation during roof replacement can make a lot of sense.

The mock-up details in the table below highlight the high-performance of McElroy Metal’s 138T Shingle Recover System in this experiment. We will address our patented 138T Shingle Recover system in depth later in this eBook. This system is ideal for both new construction and retrofit over existing shingle roofs.

	<b>MOCK-UP 1</b>	<b>MOCK-UP 2</b>	<b>MOCK-UP 3</b>	<b>MOCK-UP 4</b>
<b>ROOF TYPE</b>	Sandstone	Sandstone	Dark Bronze	Asphalt
	Metal Roof	Metal Roof	Metal Roof	Shingle
<b>ASV</b>	Yes	Yes	Yes	No
<b>SOLAR VENT</b>	Yes	No	No	No
	<b>TEMPERATURE INSIDE SIMULATED ATTIC SPACE</b>			
<b>100° AMBIENT</b>	102.3°	104.5°	113°	137.8°

# ADVANTAGES OF METAL ROOFING

## EXCELLENT SOLAR HOST

Whether your interest in solar energy stems from a desire to reduce your energy bills or carbon footprint, metal panels are an excellent host for solar energy systems. First, metal roofs offer a decades-long service life, so there is little risk the solar panels will outlive the service life of the metal roofing. The same simply can't be said for installing solar systems over shingles or membrane-type roofs.

Beyond life expectancy, both thin-film and crystalline solar modules can be attached directly to standing seam metal roofing without penetrating the roof. Since roof penetrations can lead to future roof leaks, that's a significant advantage.

Flexibility is another major advantage of metal roofing. Perhaps you're not ready to invest in solar yet. Or maybe you aren't convinced about the return on investment. That's not a problem with metal roofing. Install metal roofing now, and if you decide to add solar later (or the government mandates it), you've already installed the perfect hosting system. You can simply proceed to a solar installation at a later date without making any modifications to your existing roof. That's precisely the path we took at our manufacturing facility in Clinton, IL, pictured below.

If you're interested in learning more about solar energy and metal panels, [check this out.](#)





# ADVANTAGES OF METAL ROOFING

## METAL ROOFING & RECYCLING

Metal roofing also contains a high percentage of recycled materials, so today's metal roof could have been a refrigerator or old automobile in its past life. And, when the service life of a metal roof ends (decades after installation!), the material is recycled once again.

Shingles represent a much more significant challenge than metal and typically end up in landfills. Many local landfills have more shingles than they care to accept and charge exorbitant fees to discard shingles. Every year, 11 million tons of shingles find their way from an existing project to the landfill. To offer some perspective, that means 785,714 dump trucks annually make their way to landfills using fuel and increasing our carbon footprint, all to simply dispose of worn-out shingles.



## FIRE, HAIL & WIND-RESISTANT

Metal roofing also does a great job of standing toe-to-toe against Mother Nature. There are plenty of examples of metal roofing's performance in adverse conditions.

- An [ABC Nightly News story](#) about a metal roof surviving a forest fire.
- A [New York Times article](#) about a home surviving Hurricane Florence.
- After the devastation Hurricane Irma caused in the Florida Keys, there are calls to make [metal roofing mandatory](#) in Monroe County.
- Many insurance companies recognize the benefits of metal and offer discounts for structures with metal roofs.

# ADVANTAGES OF METAL ROOFING

## AESTHETICALLY PLEASING

It's hard to dispute that metal roofing enhances curb appeal. As you're traveling, just take a look at buildings that jump out as being attractive. There is an excellent chance that they feature metal roofs. Today's metal roofs are available in various styles and colors to fit almost any design palette and building style.



Panel styles run from exposed fastener to concealed fastener and vertical rib to tile shapes. Many manufacturers even offer a metal panel that looks like asphalt shingles for building owners that want the long-term performance of metal but the appearance of shingles.

# INSTALLATION APPROACHES-REMOVE & REPLACE VS. RECOVER

There are two main approaches to roof replacement when moving away from shingle and towards metal roofing. They are: Remove & Replace vs. Recover

**REMOVE & REPLACE:** As the name implies, the Remove and Replace approach involves removing the existing shingle roof and installing new metal panels. Depending on the roofing assembly and the scope of work, the Remove and Replace approach can expose the building, employees, and contents to mother nature during the re-roofing process.

In some cases, after removal of the existing roof materials, installation proceeds with the new materials. Yet, in others, replacing some of the decking material may be necessary due to age, water intrusion, or deck softness. If you're not sure what's best for your project, reach out to a reputable metal roof installer for input. Not sure who to call? Check out our

[Find A Contractor platform](#) to help you locate professionals close to you.



Regardless of the extent of work planned, replacing your shingle roof via the Remove and Replace approach often carries unintended consequences due to code requirements. Section C-503 of the International Energy Conservation Code (IECC) requires owners to bring the building up to current insulation requirements when altering a structure, including a Remove and Replace roof modification. It's important to note that the same code exempts roof Recovers from this requirement.

Between possible exposure to weather elements, the costs of either halting or relocating business operations and a requirement to meet the stringent IECC building codes, the Remove and Replace approach tends to be on the high end of both risk and system cost.

**RECOVER:** While a Remove and Replace system involves tearing off the existing shingles, a Recover system leaves the existing shingles in place. Because the existing roof remains in place, there is little likelihood of water intrusion into the building.

Consequently, a Recover approach typically carries the lowest owner impact. While there are always unique situations, business operations typically continue as usual. Additionally, disposal fees and labor are minimized since this approach leaves existing shingles and underlayments in place.

There are several different approaches to recovering an existing shingle roof. Some contractors like to use furring strips in a single or cross-grid application as shown below.

# INSTALLATION APPROACHES-REMOVE & REPLACE VS. RECOVER



NOTES: The image above is simply one example of a furring strip application and should not be assumed to be the only approach. The copper elements in pressure treated wood may aggressively attack metal panels. Consequently, if using pressure treated wood for furring applications, a barrier of #30 felt or synthetic underlayment should be used between the wood framing and metal panels.

Others prefer a direct to shingle attachment with a vapor barrier or thin insulation board between the shingles and the new metal roof panels. Ultimately, there are pros and cons for each approach so it's best to discuss the system design with the roofing contractor who will be performing the work. With that said, don't hesitate to [contact us](#) along the way if you'd like to discuss your project specifics with one of our experts.

Lastly, as mentioned earlier, the stringent IECC energy code requirements exempt Recover work. Consequently, you are in control of whether you decide to add additional insulation. In some cases, it may make sense to you from an energy efficiency standpoint, but in others, it may not. The most significant difference is that YOU (instead of local building officials) can determine if the money to install additional insulation provides a return on investment.

# METAL ROOFING OPTIONS

As building owners begin to explore using metal panels instead of shingles, it's important to start with some basic product knowledge.

## COLOR & PAINT SYSTEM OPTIONS

Admittedly the wide variety of colors is one of the outstanding features of metal roofing and siding. Many owners find that one of our standard colors suits their needs. While others we work with opt to have material painted with a custom color to match their corporate colors as shown in the images below.



Regardless of which path you take, it's important to select the best available paint system. After all, your building is a reflection of you and the customers you hope to attract and retain. Consequently, it's important to consider the paint system as well. Depending on the manufacturer you're working with, you may be faced with the option of a Silicone Modified Polyester (SMP) paint system or a polyvinylidene (PVDF) system which is often marketed under the trade name of Kynar 500®. While SMP systems are a bit less expensive, they are often subject to fade and chalk as shown in the image below.

# METAL ROOFING OPTIONS

Kynar 500®

SMP



Both PVDF (Kynar 500) and Silicone-Modified Polyester (SMP) panels were installed on this home in Louisiana. On day one, the colors were an identical shade of green. The above photo, taken only eight years after installation, tells a powerful story of the differences between the paint systems as it highlights both chalk and fade of the SMP paint system. Note that there is no visible fade or chalking on the darker (Kynar 500) panels.

Consequently, if curb appeal is important to you and your customers, you'll likely want to work with a manufacturer who stocks Kynar 500 paint systems as a standard offering. Not all manufacturers have taken an inventory position in this superior paint system; however, McElroy Metal is pleased to offer it as a standard stocked item for our post-frame commercial, and architectural products. You can [learn more about the differences here](#).

## EXPOSED VS. CONCEALED FASTENED SYSTEMS

One of the most significant differences between metal panel systems involves the attachment to the deck or substructure. As the name might imply, exposed fastener panels install with a screw that pierces through the metal panel and into the deck or purlin material. After installation, the screw remains visible. Conversely, concealed fastener systems attach with a clip and hidden fastener or the use of a screw through a pre-punched flange. The next panel then covers the panel connection, so there are no exposed fasteners.

There are pros and cons for both attachment methods. Exposed fastener systems tend to be less expensive than concealed fastener systems because the panels are typically twice as wide and install much quicker. That said, the panel width isn't the only reason concealed fastened panels tend to cost more, and [you can read about some of the other factors here](#). Bottom line, much like everything in life, there are tradeoffs in the decision between exposed and concealed fastener metal panel systems. That's why we've [created tips like this](#) to help our contractors guide customers to the most appropriate system selection given their expectations for longevity, appetite for required maintenance, and initial project budget.

# METAL ROOFING OPTIONS

## CONCEALED FASTENER OPTIONS

Concealed fastener systems are often referred to as standing seam panels. This product family offers a few additional features that bear consideration.

**PAN CONDITIONS:** Concealed fastener panels also typically offer different pan conditions in between the two vertical legs. Standard options range from flat to pencil ribs and striations. While the pan condition rarely affects the cost, some options like striations can greatly minimize [oil canning](#).



**SYMMETRICAL VS. ASYMMETRICAL:** The most significant differences between symmetrical and asymmetrical panels involve their appearance before installation and the ease of modification during the roof's life. Let's start first by looking at the panel shape. As you can see in the image below, asymmetrical panels look different at the top of the panel leg on the left vs. right side, while the legs on symmetrical panels mirror each other.

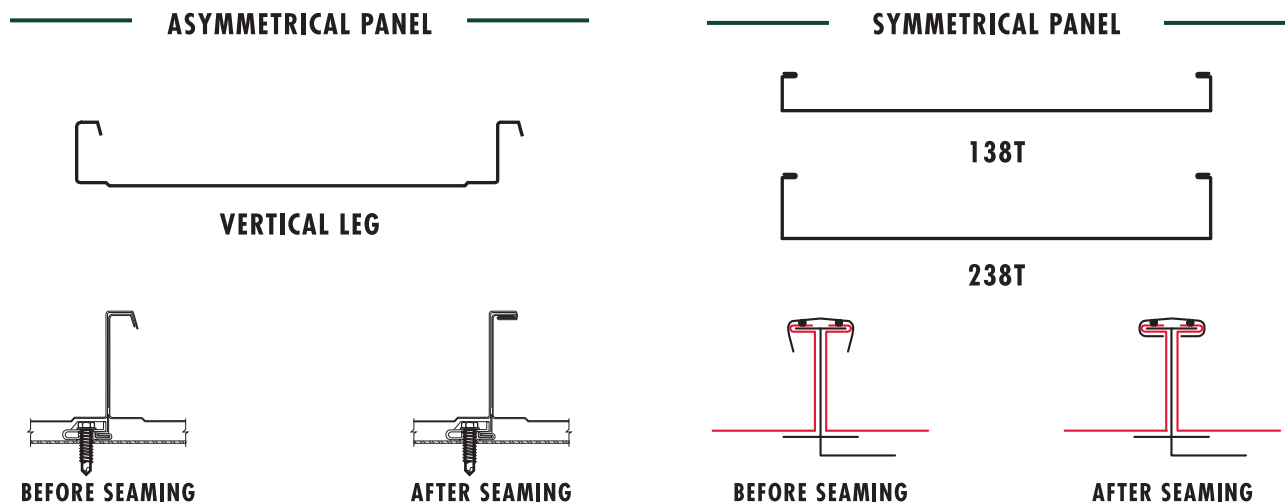

While the shapes look very different, it may be difficult to distinguish one system type from the other after installation. That is unless the panels need to be removed or replaced. If a modification becomes necessary during the roofing system's life, there is simply no comparison between a symmetrical and asymmetrical system. And remember, since metal roofs can [last 50-60 years](#), there's a decent chance that modifications or repairs will be necessary at some point over the life of the roof.

# METAL ROOFING OPTIONS

Due to their panel design, asymmetrical systems feature a male/female connection which means that during installation, the panels lock into each other. As you can imagine, it can be difficult, if not impossible, for contractors to disengage the lock between the two panels and remove a single panel in the field of the roof. Instead, they often find it necessary to remove unaffected roof panels to access the area requiring modifications or repairs.

Conversely, the panels in symmetrical systems simply butt against each other, and a seam cap covers the panel splice. The seam cap can be easily removed should modifications or repairs be necessary during the roof system's life. [Click here](#) to view a video of our unseaming machine and better understand the benefits of symmetrical standing seam roof systems.

As the video illustrates, the machine walks the panel and opens the cap back to its original shape, leaving the panel undamaged. After seam cap removal, panels can be easily removed and replaced or even reinstalled. Conversely, asymmetrical panels simply do not offer an option for easy repair.

Why is symmetry so important? Let's assume that a storm with high-velocity winds sends debris or even a tree branch onto a roof. The good news is that the metal roof likely resists the high winds, remains intact, and keeps the building protected and dry. The bad news could be that the debris leaves some cosmetic or structural damage to a roof section. The great news is that individual damaged panels can easily be removed and replaced with a symmetrical standing seam system, and the same simply can't be assumed with asymmetrical panels.



Another difference between the two systems involves panel installation. Based on their panel design, asymmetrical panels require starting at one side of the roofing and working consecutively across the roof. A left-to-right installation is the most common. Conversely, symmetrical panels do not require sequential nor left to right installs. Instead, crews can start in the middle of the roof if they want, skip curbs or spots where they are waiting for other trades, and simply come back when the area is ready for them. This feature alone can easily lead to quicker and better installs for symmetrical panels vs. their asymmetrical counterparts.



# METAL ROOFING OPTIONS

**FASTENING FLANGE VS. CLIPPED:** Standing seam (or concealed fastened panels) attach to the substructure with either clips or a direct attachment via a fastening flange. The fastening flange is a less expensive option since it isn't necessary to purchase separate clips. These cliplless systems also install faster since crew members aren't required to carry clips with them and ensure proper clip spacing and position. The images below show the slotted flange for fastener installation, and the chart on the right indicates the spacing for various deck thicknesses. Once the installer has this information, they simply skip the appropriate number of slots and install fasteners into the pre-punched slot with no need to measure.

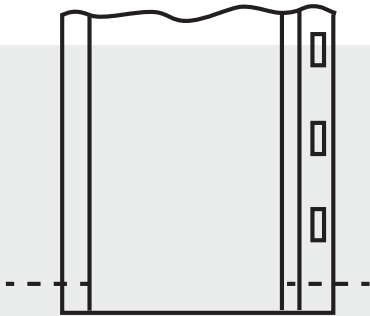

## FASTENER SPACING

Maximum Recommended Fastener Spacing For 16" wide 26 GA panels.

<u>Deck Thickness</u>	<u>Spacing</u>
1/2"	18" o.c.
5/8"	21" o.c.
3/4"	24" o.c.

While panels with a slotted fastening flange represent the most cost-effective concealed fastener system, these types of panels do present some limitations over their clipped counterparts. Metal roof panels expand and contract throughout the day as temperatures rise and fall. This phenomenon is known as thermal cycling. In fastening flange systems, the panel can only expand to the extent that the slot allows, whereas clipped systems offer much greater flexibility for expansion and contraction. For example, the clip shown below allows for up 3" of thermal movement. If you're not sure how much thermal expansion your project has, [give this a read](#) or reach out to a local engineer who can quickly run the numbers for you.

Another benefit of clipped systems is that they frequently offer better uplift testing than fastening flange systems. This enhanced performance is due to the heavier panel and clip gauge used for clipped systems vs. flange fastened systems.

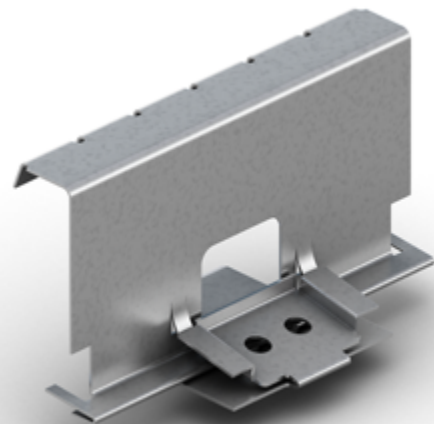

# METAL ROOFING OPTIONS

**SNAPPED VS. MECHANICALLY SEAMED:** Another differentiating factor between concealed fastener systems involves panel engagement. The male and female legs on snap-style systems engage with each other simply by applying pressure on the top panel until you hear and feel it click into place.



Mechanically seamed systems require using a motorized seaming machine to roll form the panel legs together during installation. While this step adds both labor and machine rental, mechanically seamed systems typically outperform all other systems with regard to wind uplift and water penetration. Consequently, they are a favored choice for low-slope and high-end projects. [Click here](#) to see a seaming machine in action.

**WEATHERTIGHTNESS WARRANTY:** A Weathertightness Warranty (WTW) is intended to be an assurance from a metal roofing manufacturer that a newly installed concealed fastener roof will not leak for a specified time. These programs resemble an ala carte menu where building owners select various term lengths, points of liability, and coverage amounts.

It's important to note that some manufacturers promote WTW's heavily, while others leave them to customer discretion. If you're not sure where you stand on the topic, you might benefit from reading our blog, ["Are Weathertightness Warranties Worth the Money."](#) WTW's vary widely by the manufacturer, so if you're interested in adding this protection, visit with your chosen manufacturer and installer at the outset of your project. You can learn more about McElroy Metal's weathertightness warranty offering by [clicking here](#).



# METAL PANEL STYLES



While exposed fastener panels “can” be used on commercial projects, building owners tend to select concealed fastener panels with much higher frequency. Consequently, the following section focuses on common standing seam (concealed fastener) panel styles.

If you’d like to see options for exposed fastener panels, you can view our product offering by [clicking here](#).

## POPULAR CONCEALED FASTENER STYLES

For building owners interested in concealed fastener systems, check out a few of our most popular products below.

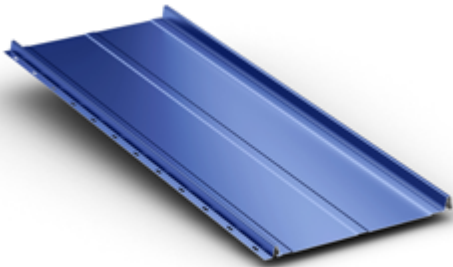

**MERIDIAN:** With a major rib just under 1” tall, the Meridian offers a great aesthetic look for smaller stature buildings with a 3:12 pitch or greater. This asymmetrical panel (left to right install) provides a 12” or 16” pan width and snaps together for easy installation. Since the panel is clipless and uses a pre-punched flange for attachment to the substructure, it represents the most economical option for a concealed fastener panel in light commercial applications. NOTE: A weathertightness warranty is not available with this product.

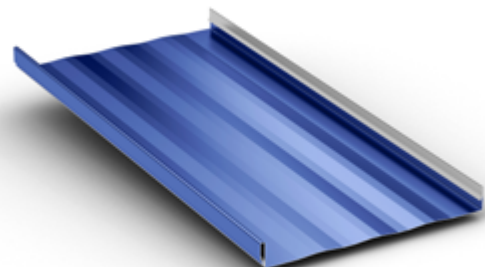

**MEDALLION LOK:** With a 1 3/4” rib height and panel widths of 12”, 16” or 18”, Medallion Lok is an attractive panel most commonly produced in 24 Ga. This asymmetrical system (think left to right installation) requires a 3:12 minimum slope and involves attaching a clip to the substructure before snapping the panels into place. NOTE: A weathertightness warranty is available with this product.

# METAL PANEL STYLES

---

## POPULAR CONCEALED FASTENER STYLES (CONTINUED)

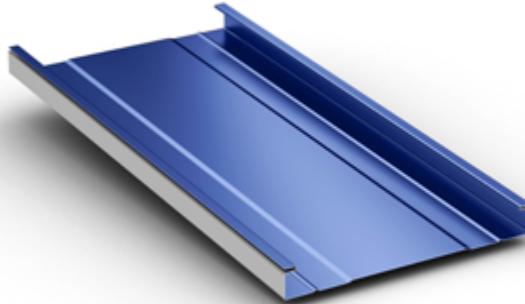

**138T/238T:** The 138T/238T systems offer a 1 3/8" or 2 3/8" rib height and panel widths of 12", 16" or 18". This system also requires a clip attached to the substructure; however, it does not require a left-to-right installation. Unlike our [Meridian](#) and [Medallion-Lok](#), it is a symmetrical panel, which decreases install time and scrap. But perhaps most importantly, as mentioned earlier, it allows for single panel replacement after the initial roofing project is complete. The 138T system requires a 2:12 minimum slope and the 238T requires a 1/2: pitch, so it's ideal for low-sloped applications. Both systems do require the use of a seaming machine. NOTE: A weathertightness warranty is available with this product.

## MCELROY METAL'S 138T SHINGLE RECOVER SYSTEM

We've also used our 138T panel to develop a patented shingle recover system. Since [McElroy Metal's 138T Shingle Recover System](#) is symmetrical, it provides all the advantages highlighted previously in addition to labor and material savings. First, in most cases, existing shingles can be left in place, eliminating the labor and expense of removing and disposing of the worn-out shingles. Leaving shingles in place means less mess, noise, and most importantly for business owners, less interruption to your business operations!

# METAL PANEL STYLES

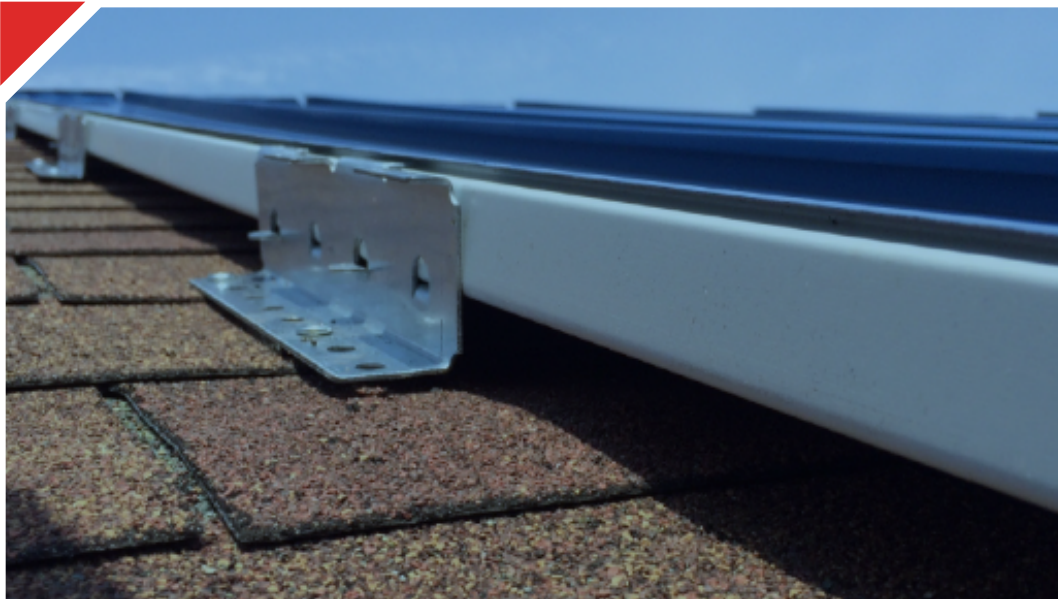

As shown in the image above, the 138T roofing panels patented clip system automatically creates the Above Sheathing Ventilation airspace, meaning the panels do not come in contact with the existing shingle roof, which eliminates the material cost and labor to apply an underlayment. [Click here](#) for an animation highlighting the components of the Shingle Recover System.

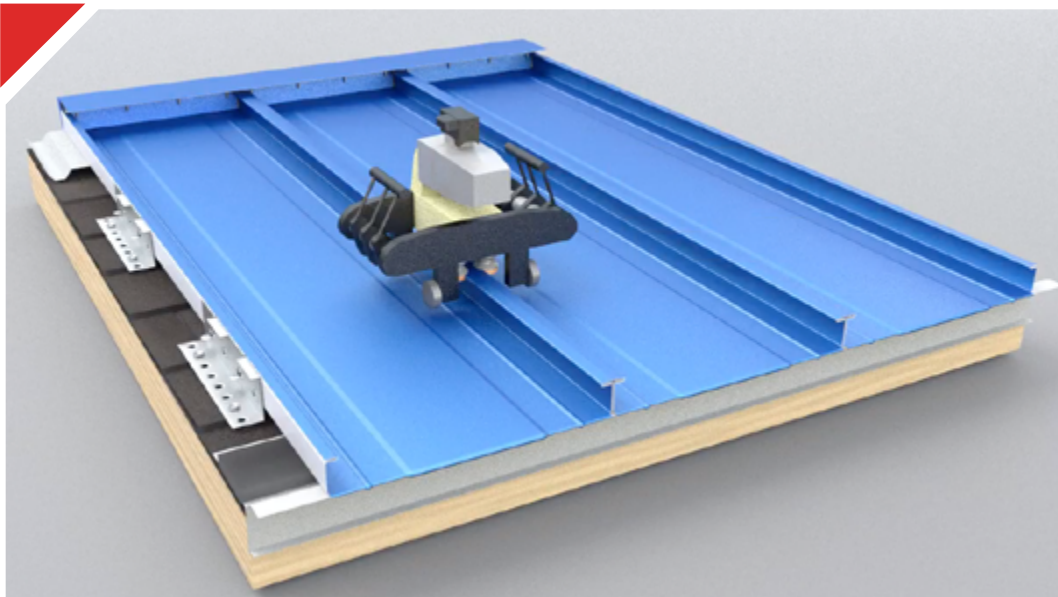

**PANEL STYLES SUMMARY:** Not sure which product type is best for your project, [contact us.](#) We're happy to help direct you once we know more about your building specifics and goals.

# PROJECT SPOTLIGHTS

## PROJECT SPOTLIGHTS OF OUR 138T SHINGLE RECOVER SYSTEM

The original building for the Alexander II Magnet School in Macon, Ga., was completed in 1902. Several significant additions through the years have brought the entire facility up to 41,650 square feet. In June 2000, Alexander II was named to the 11 Most Endangered Historic Places list by the National Trust for Historic Preservation. In 2018, McElroy Metal's 138T Shingle Recover system restored the school roof functionality while adding beauty. [Click here](#) to learn more about this recover project.

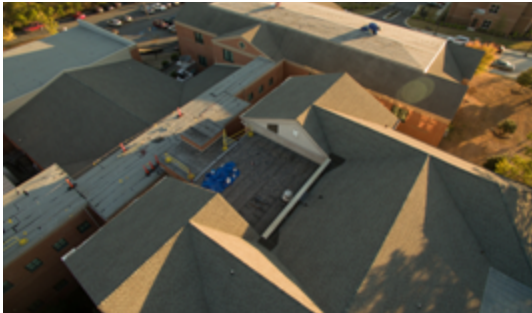

The Westlake Gardens Grand Hall event center in Indianapolis, IN, also utilized McElroy Metal's 138T Shingle Recover system in 2017 to transform their building from ordinary to fabulous. [Click here](#) to learn more about this recover project.



# CHOOSING A PARTNER

Selecting a qualified partner for the re-roofing journey is critical. While there are plenty of people and companies advising on roofing issues, few have the experience of McElroy Metal. We have been in the metal roofing business and solving problems for more than 55 years.

## WHAT'S OUR STORY?

McElroy Metal has been involved in thousands of jobs and tens of millions of square feet of roof recover projects and has seen almost every problem there is. Additionally, we hold numerous patents and are a trusted education partner of RCI (Roofing Consultants International). Our National Recover Manager, Charlie Smith, co-authored RCI's two-day Metal Roofing course and is a sought-after speaker at industry trade shows and events. Interested in setting up a meeting with Charlie, [click here](#).

We also have a rigorous testing program to ensure our systems perform as designed in real-life applications. Our in-house ASTM E1592 Test Chamber is a valuable asset that enables our engineers to test the wind uplift capabilities of our many systems. [Here is a video](#) of a test taken to the failure point; check it out.

Our team loves to use their experience to help business owners find solutions that fix their problems for the long term while delivering the best possible value.

But admittedly, McElroy Metal isn't the only game in town. For owners looking for options outside of McElroy Metal, there are some key considerations. The next section of this eBook discusses these concepts in-depth and even offers some questions to ask when interviewing potential partners.

## LEVEL OF RE-ROOFING EXPERTISE

It is vital to select a partner with extensive knowledge and experience on the topic of re-roofing. Re-roofing knowledge is different than knowledge about general roofing practices. Re-roofing is an area of specialty within the roofing industry and consequently requires an entirely different level of expertise. The best way to determine someone's experience level is to vet them thoroughly by checking references and asking questions like those below.



# QUESTIONS TO ASK POTENTIAL MANUFACTURERS AND INSTALLERS

QUESTION	KEY THINGS TO LISTEN FOR IN RESPONSE
<p><b>How many square feet of metal roofing have you installed?</b></p>	<p>Metal roofing requires an entirely different skill set than installing shingles. It's not to say that the same company can't do both successfully, but you'll undoubtedly want to ask questions to determine their experience with metal roofing. The last thing you want is for them to learn on your project.</p>
<p><b>What different types of metal roof systems have you used?</b></p>	<p>This question is your chance to learn the level of experience. We've discussed various metal roofing systems throughout this eBook and highlighted how the project specifics determine the best panel selection. Suppose you're considering working with a manufacturer or installer who has experience with only one system. In that case, it could mean they push building owners to that system regardless of the project specifics or that they have limited experience with metal roofing. Neither scenario is good.</p>
<p><b>Which system is preferred and why?</b></p>	<p>This question is also a deeper dive into the experience level. Think of it like this: are you passionate about what works, doesn't work, and why in your business? Of course, you are, so you'll want to see that same level of experience and passion in the partners you select for your metal roof project. If they can't provide you with concrete reasons for their recommendation of one product over another, they may not be the best fit.</p>
<p><b>What manufacturer certification classes have you completed?</b></p>	<p>Most reputable manufacturers offer certification programs to teach contractors general tips and proper assembly for their specific systems. It could be a red flag if a manufacturer you are considering doesn't offer certification training or the contractor you're considering hasn't completed any manufacturer training.</p>
<p><b>How long has the contractor been certified?</b></p>	<p>While it's certainly commendable to learn a new skill, none of us want to be the guinea pig. Inquiring about the length of contractor certification can open a good discussion about their business model and experience.</p>
<p><b>How many projects have you installed?</b></p>	<p>Like other new skills, contractors specializing in recover work see new conditions and challenges on every project. While there are no hard and fast guidelines here, a good rule of thumb involves partnering with manufacturers and installers who have completed a minimum of twenty project installs.</p>
<p><b>How many of the installer's previous projects have been non-warrantable?</b></p>	<p>Weather-tightness warranty projects require the panel manufacturer to "accept" the installation before issuing the warranty. If one of your potential installers could not obtain a weather-tightness warranty due to installation errors, it would be a red flag and indicate possible quality concerns.</p>
<p><b>Are they part of an extensive, factory-backed, certified dealer network?</b></p>	<p>A certified dealer network reduces costs and adds confidence the new roof will be correctly installed.</p> <p>McElroy Metal has 25 certified manufacturer/installers who own the equipment to manufacture and install the 238T and 138T roof systems and over 500 who have completed our two-day hands-on training class. This team of highly qualified contractors can help you solve your problem with the highest quality solution at the lowest possible cost.</p>
<p><b>What types of substrates, paint systems, and gauges does the manufacturer offer?</b></p>	<p>Questions like this help you determine how your new roof will not only perform but also look in the years to come. To learn more, check out our recent eBook entitled, "<a href="#">What's Better - A National or Regional Metal Panel Manufacturer?</a>"</p>



# SUMMARY

---

Admittedly replacing a roof consumes a business owner's time, money, and focus, and there's simply no doubt that all three of those things are in high demand.

As we've discussed throughout this eBook, metal roofing offers the following benefits:

- **50 to 60-year service life**
- Excellent host for solar energy
- Low maintenance
- Energy-efficient for lower utility expense
- Environmentally friendly with high recycled content
- Highly resistant to Mother Nature's elements and fury
- And, metal roofing looks great - adding curb appeal to any project

When the time comes to replace your shingle roof, let our team of experienced employees and nationwide contractors provide the expertise you need to make a metal roof your last roof.

[Contact us](#) to start the conversation!

## ABOUT MCELROY METAL

Incorporated in 1963, McElroy Metal is a third-generation family-owned and operated business. McElroy Metal holdings include 13 manufacturing locations and 25 Service Centers located throughout the United States. One of our specialties is helping our customers develop solutions using metal roofing and siding.



### CONTACT US:

[www.mcelroymetal.com](http://www.mcelroymetal.com)

1500 Hamilton Road, Bossier City, LA 71111

318.747.8000

[info@mcelroymetal.com](mailto:info@mcelroymetal.com)